

**MARITIME TRANSPORTATION RESEARCH AND EDUCATION CENTER  
TIER 1 UNIVERSITY TRANSPORTATION CENTER  
U.S. DEPARTMENT OF TRANSPORTATION**



**Development of Multi-Axial Fatigue Retrofits for Waterway Lock  
Gate Components**

**August 1, 2018 to March 31, 2021**

**Prepared by:**

**Logan Verkamp  
Gary S. Prinz, Ph.D., P.E. (Project PI)  
Department of Civil Engineering,  
University of Arkansas, Fayetteville,  
4190 Bell Engineering Center,  
Fayetteville AR, 72701**

**March 2021**

**FINAL RESEARCH REPORT**

**Prepared for:**

**Maritime Transportation Research and Education Center**

**University of Arkansas  
4190 Bell Engineering Center  
Fayetteville, AR 72701  
479-575-6021**

## **Acknowledgements**

This material is based upon work supported by the U.S. Department of Transportation under Grant Award Number 69A3551747130. The work was conducted through the Maritime Transportation Research and Education Center at the University of Arkansas.

DISCLAIMER The contents of this report reflect the views of the authors, who are responsible for the facts and the accuracy of the information presented herein. This document is disseminated in the interest of information exchange. The report is funded, partially or entirely, by a grant from the U.S. Department of Transportation's University Transportation Centers Program. However, the U.S. Government assumes no liability for the contents or use thereof.

## Report Summary

Lock gates are essential infrastructure components to the United State (US) supply chain. They create large cost savings and environmental benefits when compared with traditional methods of transport (freight and rail). Because of the large quantity of goods and dependence on these shipping chains, the US economy can be drastically affected by an unexpected gate closure. Unfortunately, many lock gates within the US have reached or exceeded their designed life. Due to the intensity of cyclic loads and the environment, fatigue cracks have become a prominent issue. Developed cracks near the pintle region (a joint which the gate rotates and rests upon) have shown to be difficult to mitigate due to the complex stresses that flow through this area. Mitigation methods commonly used for mode I cracking are often ineffective for cracks near the pintle because of the complex stress states present. These stresses are known to be multi-axial stresses which cause multi-mode cracking at the crack tips of the developed fatigue cracks.

The work presented herein is an analytical and experimental investigation into multi-axial fatigue crack mitigation by the use of carbon fiber reinforced polymer (CFRP) capable of extending gate-component fatigue life until permanent repair can occur. Detailed finite element models are used to develop and validate CFRP retrofit geometries capable of mitigating crack propagation on generalized, scaled specimens as well as a detailed model of the pintle geometry itself. Additionally, experimental crack mitigation is conducted in an attempt to validate what is found through the FEA models.

Analyses indicate that stiffened CFRP plates are effective at reducing multi-axial stresses within the pintle region, as long as the CFRP-to-steel bond remains intact. Experimental multi-axial fatigue testing highlighted difficulties in maintaining deformation compatibility between the steel and stiffened CFRP plates under out-of-plane loading (mode III loading), leading to debonding and negligible stress reductions for fatigue life improvement. Roughening the steel surface prior to attaching the CFRP plates increases the CFRP-to-steel bond strength under in-plane loading.

## Table of Contents

<b>1. Introduction</b> .....	1
1.1. <i>Overview</i> .....	1
1.2. <i>Economic Impact of Failing Waterway Infrastructure</i> .....	2
<b>2. Research Overview</b> .....	7
<b>3. Research Methodology: Analytical and Experimental Investigations</b> .....	7
3.1 <i>Finite Element Modeling of Pintle Location</i> .....	7
3.2 <i>Experimental Multi-Axial Fatigue Testing</i> .....	10
3.3 <i>FEA Modeling of Generalized Specimens to Develop CFRP Retrofits</i> .....	14
3.4 <i>Experimental Validation of CFRP Retrofits</i> .....	15
3.4.1 <i>Investigation of CFRP-to-Steel Bonding</i> .....	15
3.4.2 <i>Retrofit</i> .....	18
<b>4. Results/Discussion</b> .....	21
4.1 <i>Pintle Modeling</i> .....	21
4.2 <i>FEA Modeling of Generalized Specimens to Develop CFRP Retrofits Results</i> .....	23
4.3 <i>Retrofitted and Non-retrofitted Specimen Experimental Results</i> .....	25
<b>5. Conclusions</b> .....	31
<b>6. References</b> .....	32

## List of Figures

Figure 1. Function of lock gates within the lock system [1].....	1
Figure 2. Marine highway routes within the US [6] .....	2
Figure 3. Pintle of a Miter Gate [14].....	4
Figure 4. The 3 Modes of Cracking .....	4
Figure 5. Fatigue cracking near miter gate pintle (a) before and (b) after retrofit.....	6
Figure 6. Flowchart of Research Tasks.....	7
Figure 7. Upstream elevation and top view of a lock gate [1].....	8
Figure 8. Sub Modeled Pintle Region.....	9
Figure 9. Walter+Bai Bi-axial Fatigue Testing Machine.....	10
Figure 10. Hollow Tube specimen subject to multi-axial loadings (mode I & II).....	11
Figure 11. Plate specimen subject to multi-axial loadings (mode I & III) .....	12
Figure 12. Tube and Plate Specimens within machine grips .....	13
Figure 13. Tube and Plate specimen dimensions as modeled within Abaqus Cae .....	14
Figure 14. Three different surface preparation deformations .....	17
Figure 15. CFRP Surface preparation finished specimens .....	17
Figure 16. Layup method of CFRP showing clamps and acrylic molds .....	19
Figure 17. Steps taken to prepare retrofitted plate specimens .....	20
Figure 18. Larger 1ft by 2ft retrofit .....	22
Figure 19. FEA Model visual assistance of stress orientations (Torsion Only) .....	24
Figure 20. Contour comparisons between three different layups .....	25
Figure 21. Resulting fatigue crack growth in uni-axially loaded un-retrofitted and retrofitted notched plate specimens. ....	27
Figure 22. Resulting fatigue crack growth in un-retrofitted and retrofitted notched plate specimens under combined axial and torsional loading. ....	28
Figure 23. CFRP debonding in retrofitted notched plate specimens under combined axial and torsional loading.....	28
Figure 24. Strain Gauge placement on (a) un-retrofitted and (b) retrofitted cracked plate .....	30
Figure 25. Crack tip stresses with and without Unidirectional CFRP Retrofit.....	30

## List of Tables

Table 1. Retrofit vs non-retrofit stress reductions within the pintle model .....	21
Table 2. Retrofit vs non-retrofit stress reductions within the pintle model for 1 ft by 2ft retrofit.	22
Table 3. Axial Only stress reductions found within the FEA model.....	25
Table 4. Tabulated fatigue assessment of all tested specimens .....	26
Table 5. Stress values of an axial only plate model nearest crack vs. strain gauge location (FEA Model).....	31

# 1. Introduction

## 1.1. Overview

Lock gates allow the passage of vessels through differing water elevations often caused by the presence of dams. Without lock gates, vessels would be unable to travel along dammed rivers. As shown in Figure 1, the passage of vessels between differing water elevations requires entrance through an open gate, water elevation equalization and then exit through the opposing gate. If either gate is non-operational, passage would be limited.

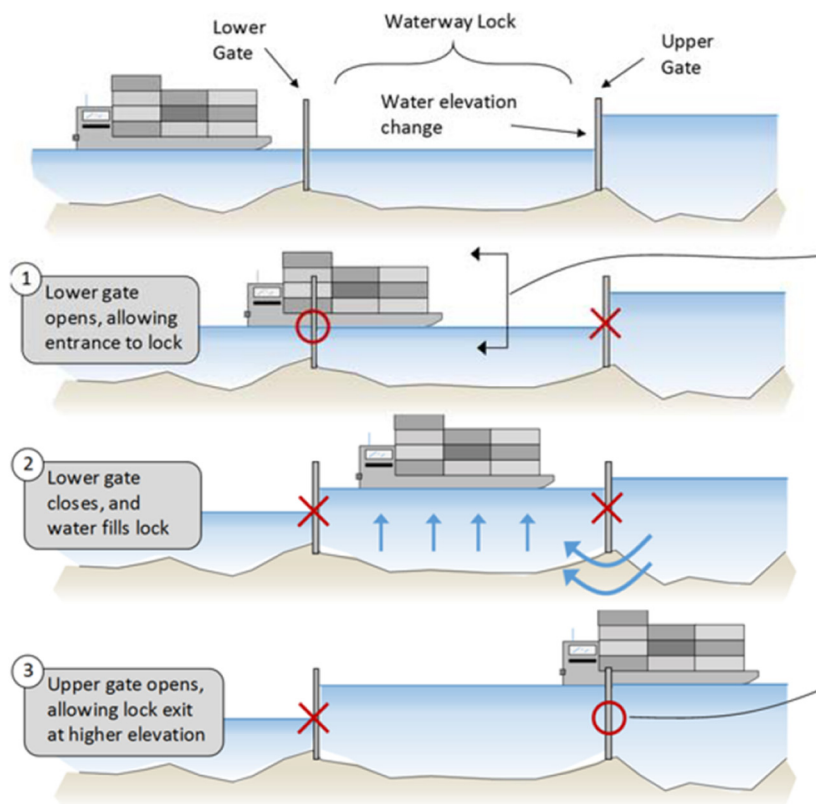

Figure 1. Function of lock gates within the lock system [1]

The United States waterway transportation infrastructure is vast, including over 12,000 miles of waterway, which has economic, security, and environmental benefits over the traditional use of rails or highway transport methods [2]. Figure 2 shows the mapped marine highway routes within the United States inland waterway system. The economic advantages of inland waterway

transportation versus traditional transportation methods (i.e. freight, or rail) provide an incentive for waterway transport and increase demand on the existing lock gate infrastructure. As an example, transportation along the inland waterway can be 5-10 times cheaper per ton of shipped material [3]. This cost difference is mostly attributed to the amounts of material a typical transport vessel, barge, can carry through a transport route. The most common type of barge used to transport goods along the major US waterways is a 15-barge tow, which is equivalent to nearly two 108-car trains or 1,050 trucks [4]. While it is true most commodities cannot solely be shipped by barge, many essential commodities rely heavily on barge transport at some point in the shipment process. For example, barge transportation along inland waterways of the Mississippi river generate an estimated transportation cost savings of a billion dollars annually [5].



Figure 2. Marine highway routes within the US [6]

## 1.2. Economic Impact of Failing Waterway Infrastructure

Due to the cost savings and dependence of shipments of essential commodities on these structures, lock gates are a major infrastructure component of the US economy. Since many of these gates are literal bottlenecks in the supply chain of essential goods, gate closures are a major



concern and must be avoided when possible. According to the US Department of Homeland Security, a 6-month gate closure of the Soo Locks connecting Lake Huron and Lake Superior would have devastating effects on the entire US economy resulting in a loss of between 12-15 million jobs, sending the entire nation into a “severe recession” [7]. Additionally, the Monongahela River system facilitates approximately 20M tons of cargo annually (much of which is coal for electric power generation). This gives rise for other aspects of the nation’s essential commodities that could be hurt by an unexpected lock closure. The Greenup Lock and Dam experienced an unscheduled extension of repairs which caused a reroute of coal shipments by alternate means as stockpiles became increasingly depleted [8]. This reroute of shipments is accompanied by major cost variations and changes within the energy generation industry. Each lock in the nation would cause some amount of distress on local and possibly national economies by the creation of a supply chain break in the event of an unexpected long-term closure.

Given the current conditions of the United States inland waterway infrastructure (which is aging) the probability of lock gate closures and disruption to transport service are increasing with each year of service. The majority of lock gates within the United States were given a design life of 50 years while the average age of these existing structures is 67 years, with a few (still in operation) being older than 100 years. Due to the age, severity of the cyclic loadings and the often corrosive environment in which lock gates operate, fatigue cracks within lock gate components are prevalent and often go unchecked until service interruption or closure for routine maintenance.

Fatigue cracks near the pintle location (a ball-and-socket joint that allows opening and closure of the gate) are particularly challenging given the complex stress states created during normal operation. Figure 3 shows a typical pintle location within a miter lock gate. At this location, fatigue cracks have been known to grow and form unexpectedly due to the types of stresses present.

The complex stresses through this location create crack tips that see combinations of the 3 modes of cracking. Mode I is the in plane opening of a crack, mode II is the in plane shear of a crack, and mode III is the out of plane shear of a crack (Figure 4).



Figure 3. Pintle of a Miter Gate [14]

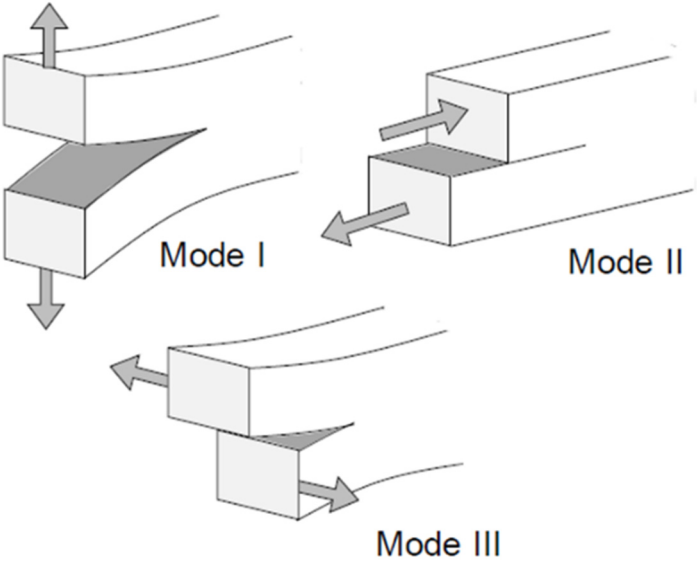

Figure 4. The 3 Modes of Cracking

When loaded under combined stresses, fatigue cracks become more difficult to mitigate, as traditional crack arrest approaches which focus on Mode I loading often don't work under combined mode loading. While research such as that by Ayatollahi [9] has been conducted to explore crack mitigation of mixed modes I and II, the mitigation technique used was stop holes which have been shown to be ineffective for these lock gate fatigue cracks that are subjected to combined Mode I and mode III. Traditional crack growth mitigation methods such as stop holes or vee-and-weld, have shown to be futile in the efforts of slowing or stopping fatigue crack growth within structures where multi-axial stresses are present. Stop holes and vee-and-weld methods have been implemented for miter gate crack arresting attempts but cracking has proven to grow past these methods (see the cracked pintle and failed retrofit in Figure 5). In addition, large physical mitigation methods such as welding require large amounts of time and coordination in order to be completed and completed effectively.

Additional research has shown carbon fiber reinforced polymer (CFRP) implementation can be successfully used on steel structures but only to strengthen plane members or mitigate mode I type cracking [1, 10-13]. To our knowledge, investigation of CFRP effectiveness in mitigating crack growth under combined mode loading has not been explored extensively; however, due to many beneficial properties, CFRP may be a viable option for arresting cracks under multi-mode fatigue loading. CFRP is resistant to corrosion, resistant to fatigue, has a high strength-to-weight ratio, has a high modulus of elasticity, and due to the makeup of CFRP fiber orientations can be varied to combat different directions of stress in desired strengthening planes. Additionally, CFRP can be applied and cured quickly, providing added benefits during repair scenarios where closure time reduction is a necessity. As an example, CFRP can be cured in as little as half an hour when using some fast setting epoxies or by the application of heat on slower setting epoxies.

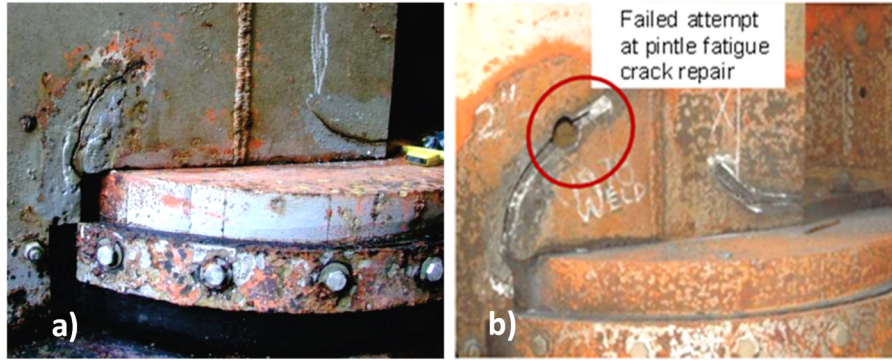

Figure 5. Fatigue cracking near miter gate pintle (a) before and (b) after retrofit

Replacement of the pintle location is a lengthy process even when scheduled and planned in advance. This process becomes significantly more difficult if a replacement is needed unexpectedly and the more unexpected a closure, the greater the effects that closure will have. In 2014 Lock and Dam 14 on the Arkansas river near Tulsa, OK underwent a full replacement and renovation of the pintle ball and bushing across a time span of 3 weeks [15]. These repairs were planned for over two years in order to acquire the necessary equipment, parts and supplies needed to complete this scale of a job in a 3-week window. If this type of replacement were done due to an unscheduled event, the time frame would drastically lengthen and only increase the impacts on transport and local, possibly national, economies.

Methods are needed to slow crack growth within lock gates and create a temporary but extended time frame to failure in order for the maintenance team to be given a significant amount of time to schedule a pre-planned replacement or permanent repair. This will not only shorten the gate closure time but also allow for the scheduling of a closure during a time that could have as few negative closure effects as possible. This report presents an analytical and experimental investigation into the mitigation and control of existing fatigue cracks under multi-axial stresses on or about the pintle location of a typical miter gate using carbon fiber polymer patches. The purpose of a CFRP patch would be to extend the service life of the pintle in order to allow for a

sufficient amount of time to plan a scheduled pintle repair. It is not intended to serve as a permanent repair to an existing fatigue crack located about the pintle. The patches ability to increase the number of service cycles for the gate will need to be of sufficient magnitude in order to extend the gate life into a window of time necessary to allow for the planning and scheduling of a more permanent repair.

## 2. Research Overview

Three detailed research tasks are described herein, focused on developing fatigue crack mitigation strategies for multi-axially loaded pintle locations. These tasks involve 1) detailed finite element modeling of gate components, 2) experimental fatigue testing of multi-axially loaded steel components and the development of retrofit strategies, and 3) investigation into retrofit effectiveness using both finite element simulations and experimental fatigue tests. A flow chart of the research methodology is shown in Figure 6.

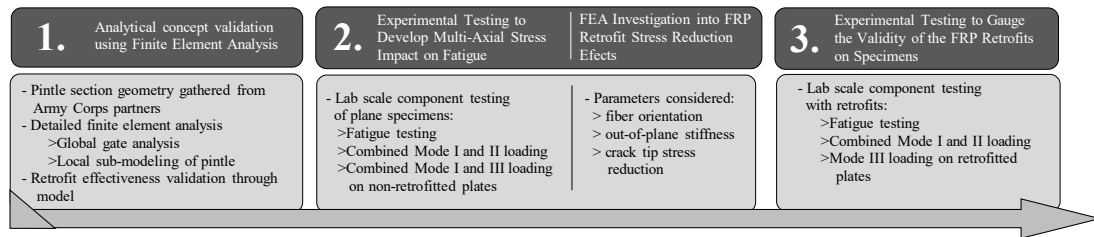

Figure 6. Flowchart of Research Tasks

## 3. Research Methodology: Analytical and Experimental Investigations

### 3.1 Finite Element Modeling of Pintle Location

The commercial finite element software ABAQUS was used for all modeling of the lock gate stress analysis [16]. A global shell element miter gate model of the Greenup Lock and Dam on the Ohio river was created to explore the global stresses caused by hydrostatic cycles on the gates in previous research [1]. The lock gate model by [1] was originally used to explore the design

of prestressed CFRP retrofits for members in plane stress states to improve fatigue life. This model was used for the current research to view the general loads, stresses, and strains throughout the entire gate to gain a better understanding of stresses felt near the pintle region and to help with the loading of a sub model of the pintle area.

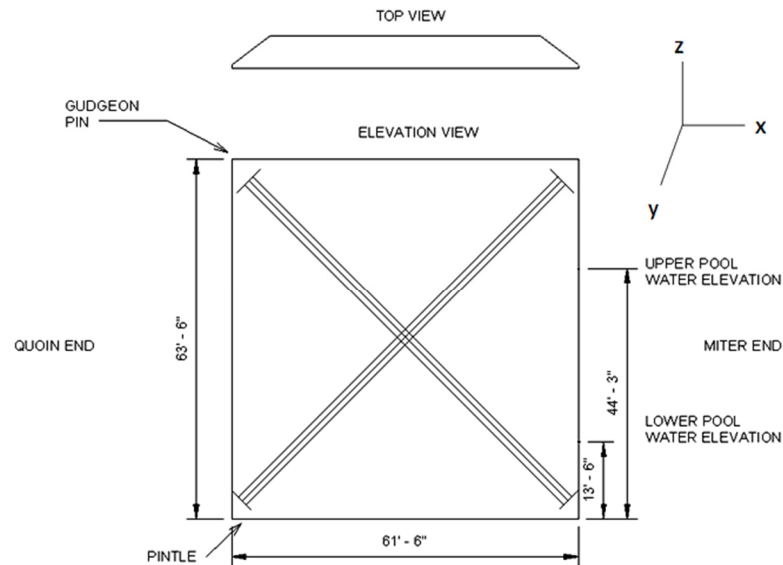

Figure 7. Upstream elevation and top view of a lock gate [1]

The sub model was created using the same construction plans used for simulating the gate in [1], however, great detail was taken into account for the smaller region to create more accuracy throughout the pintle region. The sub model of the pintle region of the gate included the pintle itself and 58 inches above the pintle flange (Figure 8). The sub model was made up of deformable solid elements. The pintle casting was meshed using 1 inch seeds and a tetrahedral free mesh due to its complex geometry. The rest of the model was meshed using a seed size of 0.75 inches and a combination of both structured and swept hexagonal meshing. The part as shown in Figure 8. was bounded in all directions on faces 1 and 2. To load the part in a simple arbitrary way, the casting was twisted and pulled to fabricate complex stresses throughout the pintle region that could then be mitigated to display validity of the CFRP retrofits upon this geometry. The pintle was twisted

0.005 radians counterclockwise as seen in Figure 8 and pulled 0.002 inches. Using the stresses created from the pulling and twisting, two regions were identified where stresses were considered to be of significant complexity and magnitude. The regions were then used to model retrofit effects by rigidly tying a CFRP retrofit using a rigid tie constraint to the region. Relative stress reductions were measured in two different zones of the region and are displayed in Figure 8 labeled “A” and “B”. Additionally, a larger flat CFRP retrofit of 1’x2’x0.15” was laid across the bottom of the pintle region to determine if retrofit size played any significant roles in stress reduction.

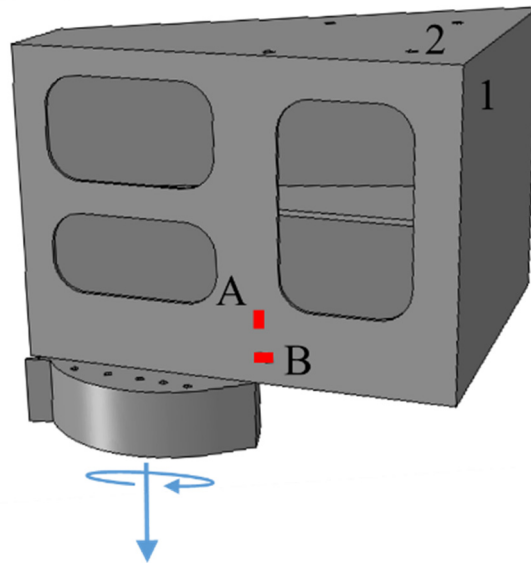

Figure 8. Sub Modeled Pintle Region

The goal of the simulations was to understand how stresses develop within the complex geometry of a lock gate pintle. The stresses flowing through this size and shape of geometry will behave similarly to a variety of stresses through similar geometries. This means a retrofits capabilities to reduce stresses can be validated through this simpler method of loading. The effects can then be correlated into theoretical improved fatigue life validating the theoretical implications of the use of CFRP as a cracking mitigation method.

### 3.2 Experimental Multi-Axial Fatigue Testing

Due to the size and complexity of the pintle region, generalized specimens were created to simulate the complex combined stress states within the pintle. Specimens were scaled and generalized only to research the effects of these complex stresses through the cracked steel materials. These generalized specimens were pre-notched to represent a pre-existing fatigue crack and then placed into a Walter-Bai bi-axial fatigue machine where they underwent cyclic loadings (Figure 9). The bi-axial machine has the capability to apply torsion and tension to the specimens which allowed for different variations of applied loading. Two different specimen geometries (as will be discussed in more detail later) consisting of plates and tubes are considered to apply different combinations of fracture modes. For example, pure tension loading would cause mode I cracking, pure torsion would cause either mode II or III, depending on which of the two geometries is being loaded, and a combination of tension and torsion caused a combination of the 3 cracking modes.

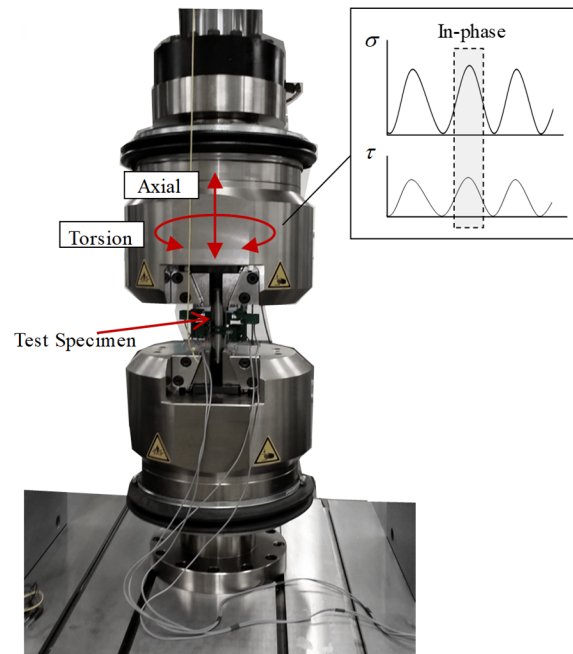

Figure 9. Walter+Bai Bi-axial Fatigue Testing Machine



To vary what modes are felt at the crack tip, certain geometries were utilized. Starting with mixed modes of I and II, a hollow tube was used and loaded as seen in Figure 10. The tube was pre-notched perpendicular to the length of the specimen. At the crack tips, both opening and in plane shear will be created when torsion and tension are applied to the tube specimen. Three different loadings will be presented to the tubes, pure axial tension (mode I), pure torsion (mode II) and a combination of the two in phase to create simultaneous multi-axial stresses (mode I & II).

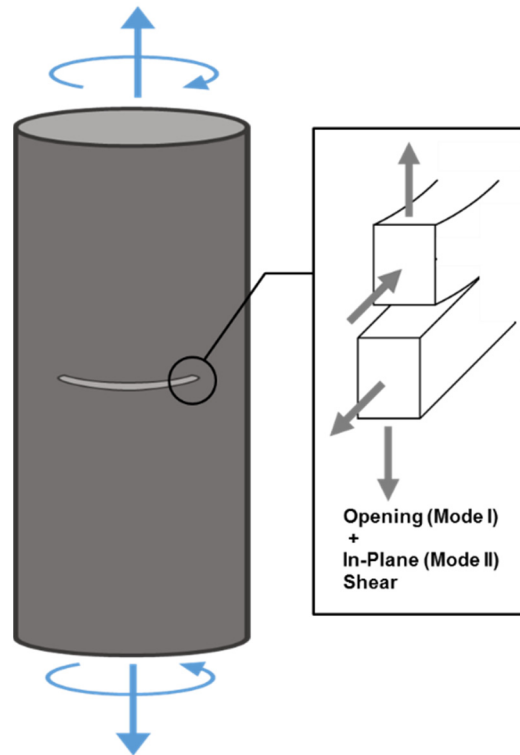

Figure 10. Hollow Tube specimen subject to multi-axial loadings (mode I & II)

Tube specimens were fabricated out of 1-1/4" schedule 40 steel pipe sections. The sections were approximately 15" from end to end, where they were pinched flat to create an area that could be gripped by the machine. The tubes were then notched using a 0.045" metal cutting disc with nominal cuts being 1.25" chord length from tip to tip. Three specimens, one for each loading

configuration, of non-retrofitted tube specimens were ran to failure. The 3 loading types were 50 kN of axial tension, 500 N\*m of torsion and an in-phase loading of the two. “Failure” was predefined within the machine constraints as 1mm of axial elongation or 3° of angular rotation, whichever came first. The machine was run at approximately 3 Hz allowing for around 11,000 cycles per hour of run time.

Modes I and II were only given one specimen per loading combination due to the origins of modes I and II. These two modes are essentially the same with respect to mitigation due to the fact that pure mode II is simply mode I rotated at 45° angle indicating that retrofits sufficient for mode I would likely be sufficient for mode II as well as modes I and II combined.

To create modes I and III, flat plates were used. Again, a notch in the plate was cut perpendicular to the axial loading. At this crack tip, tension causes mode I and torsion causes mode III to be present as seen in Figure 11.

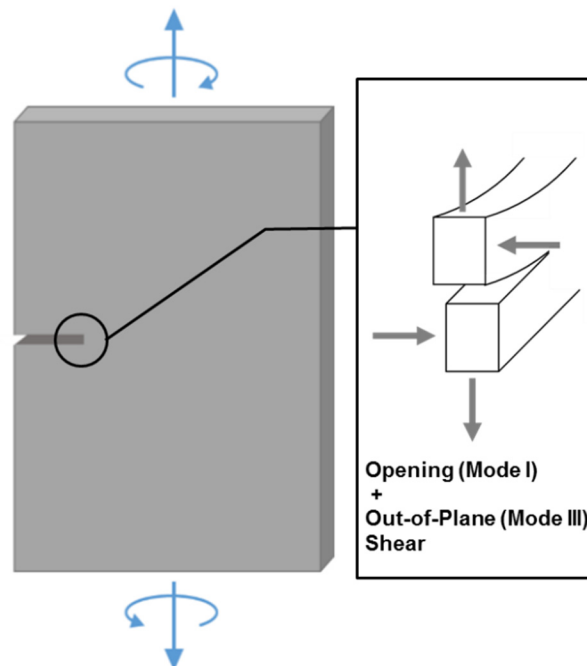

Figure 11. Plate specimen subject to multi-axial loadings (mode I & III)

Plates were fabricated using 7” of 5” wide by 3/8” thick plate steel. Notches were centered about the plate length and were created using a 0.045” metal cutting disc with a nominal length from the edge of plate to the crack tip of 0.8”. Loadings for the plate specimens were 100 kN of axial tension, 1000 N\*m of torsion and a combination of the two loads. Two specimens per the three loading types for a total of 6 non-retrofitted specimens were ran to failure. Failure for the plates was constituted by 1mm of stroke elongation or 3° of angular rotation. These failure limits were predetermined and were entered into the machine as the stop criteria or the “point of failure”. The machine was again ran at 3 Hz for each specimen. Examples of both the tube and plate specimens can be seen in Figure 12. Plate specimens were given additional specimens in order to place emphasis on the out of plane retrofitting given that the main focus of the research is placed on mode III.

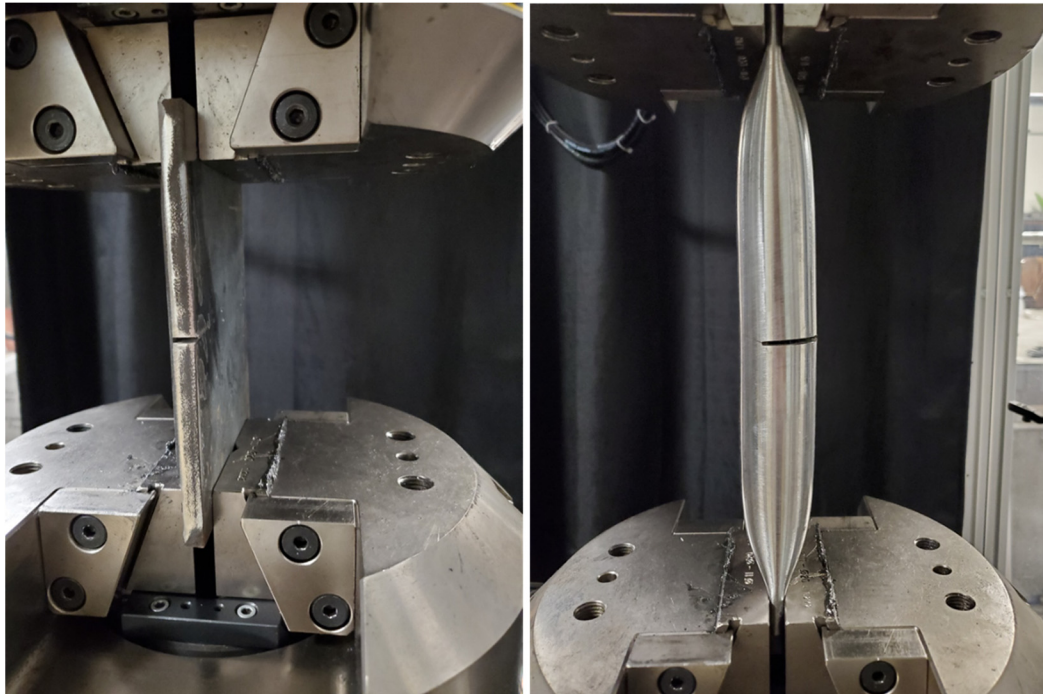

Figure 12. Tube and Plate Specimens within machine grips

### 3.3 FEA Modeling of Generalized Specimens to Develop CFRP Retrofits

To develop multi-axial retrofits efficiently, finite element analysis was used. By modeling the generalized tube and plate specimens under complex loadings, stresses and their corresponding orientations could be obtained. Not only could the directions and magnitudes of principle stresses be obtained, but visual representation of these stresses within the output database could be used to aid in developing retrofit geometries that would counteract the stresses most effectively and in turn improve crack arrest. Many different retrofit geometries could then be modeled to find the most effective retrofit for each loading type. “Retrofit effectiveness” was measured by the ability to most greatly reduce the stresses at the crack tips of the particular specimen and loading configuration.

Specimens were modeled as closely to the fabricated specimens as possible. Dimensions of the models for the tube and plate are shown in Figure 13. Crack tip geometries were given a radius equal to half the thickness of the cutting disc, 0.045”.

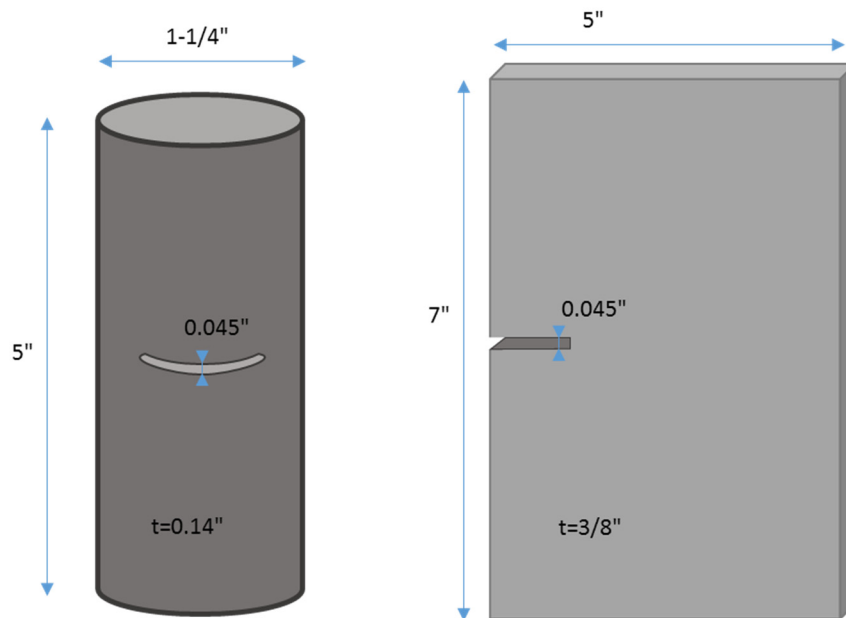

Figure 13. Tube and Plate specimen dimensions as modeled within Abaqus Cae

Both specimen geometries were given a general mesh size of 0.1” based on computational demands which was reasonable for determining stress orientations. Grips were created using rigid solid elements and all loads were applied to the top grip while the bottom grip was bounded in all directions and rotations. Tube and plate models were given the same loads as were applied during experimental testing.

For the tube specimens, loads were 50 kN of tension, 500 N-m of torsion and a model of both loads applied simultaneously. For plates, 100 kN of tension, 1000 N-m of torsion and a combined loading model. Crack tip stresses and their orientations were obtained. Stress orientation symbols were used to visualize how the specific stresses could be reduced by CFRP and what fiber orientations would be best suited for the different loadings. For torsion only, different CFRP layups were analyzed. CFRP retrofit cohesive zones were modeled on to the specimens as simple rigid tie constraints. While these tie constraints, do not account for the actual cohesive layer strength of real CFRP, they simulate how the CFRP would reduce the stresses with a perfect CFRP to steel bond. The purpose of the differing CFRP layups within different models was to find the CFRP layup that most greatly reduced the non-retrofitted crack tip stresses. All CFRP layups were given the same linear elastic properties of 32,700 ksi for the tensile modulus and were seeded using a general size of 0.1”.

### ***3.4 Experimental Validation of CFRP Retrofits***

#### ***3.4.1 Investigation of CFRP-to-Steel Bonding***

To begin the experimental testing of retrofitted tube and plate specimens, a series of surface preparation tests were conducted in addition to literature reviews on CFRP bonding studies to better prepare for applying CFRP retrofits [17]. These tests were to increase the bond strength between the steel and CFRP to maximize the effectiveness of the retrofits. Three single layer shear

tests were conducted using two individual plates with respective surface finishes bonded by a single strip of CFRP. The specimens were made to be identical in all aspects but surface preparation. All specimens were created to have nominal dimensions of bond area of 1.9” by 1.8”. Prior to any varying surface preparations, mill scale was removed using 80 grit sandpaper discs and surface particulates were removed with acetone. Surfaces were then given three surface preparations including: 40 grit sanding perpendicular to the applied force, square pyramid indentations, and chisel and hammer indentations to create large deformations and micro welds on the surface of the steel (Figure 14).

After surface preparation was complete, CFRP was applied to both strips in a similar manner that would be used for future retrofitted specimens and allowed to cure overnight. All specimen edges were then sanded flush with the sides of the steel and the ends of the CFRP were filed to the nominal dimensions of the desired CFRP cohesive layer. The far edges of the CFRP were sanded to 45° to reduce adhesive shear and peel stresses in all specimens as suggested within [13], (Figure 15). Specimens were then placed into the Walter+Bai bi-axial fatigue machine to test.

The experimental CFRP bond test only applied tension in a displacement-controlled setting. By applying tension to specimens with only one side reinforced by CFRP, some eccentricity was present, indicating a slight peeling effect from the center of the specimen out would occur but due to the relatively short lengths of the steel and the loads applied, peeling due to eccentricity was thought to be negligible. This test setup also accurately represents how the CFRP would be applied within the field and therefore results are applicable to this research when verifying the best surface preparation method. Tests were conducted at .01 mm/s until full failure of the bond. Max loads were recorded and used to select the “best” surface preparation for this type of loading.

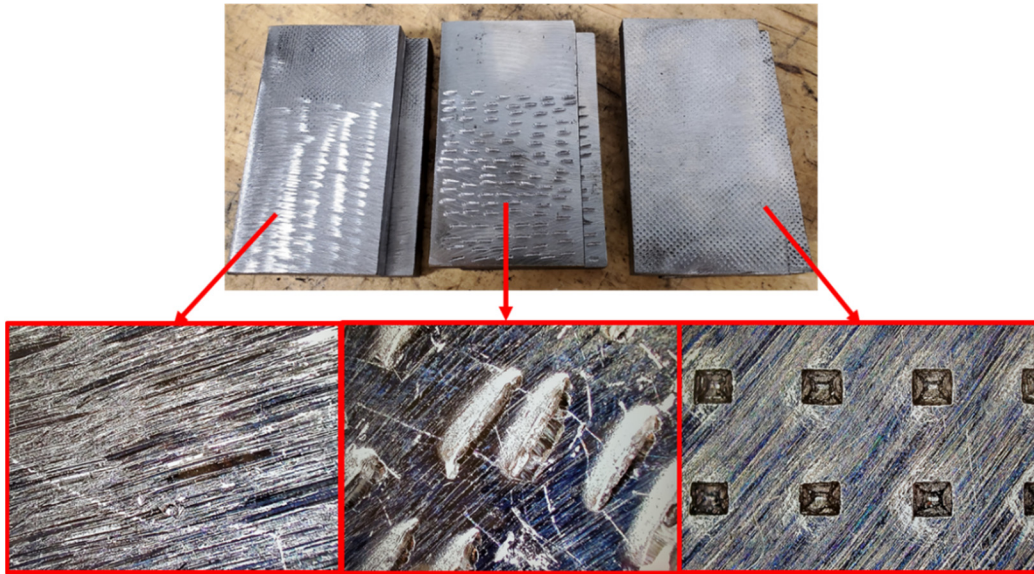

Figure 14. Three different surface preparation deformations

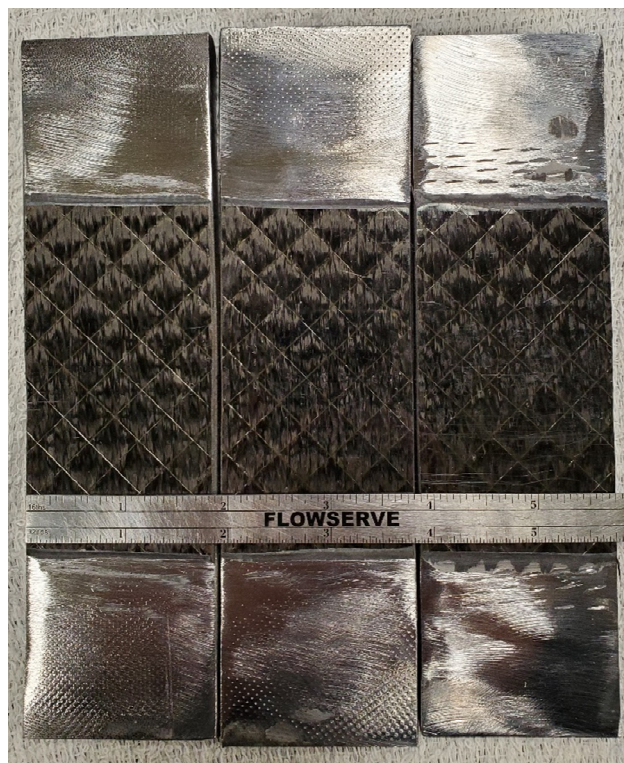

Figure 15. CFRP Surface preparation finished specimens

### **3.4.2 Retrofit**

All retrofits were fabricated using the same bonding methods with only variations in the CFRP configuration design above the cohesive layer. This CFRP configuration was varied dependent on the particular loading the specimen would see. All plate specimens were bonded on one side only. The bond location on all steel would be sanded until all mill scale and surface corrosion was clear. The surface would then be wiped with a solvent such as acetone to clean it of all oils and smaller particles. The most shear and peel stress resistant surface preparation was then used for all retrofits. After prepping the surface with the desired treatment, acetone was again used to clean off any additional oils or particles once more. A two-part 2000 series laminating epoxy resin was used for all retrofits purchased from FibreGlast.com. This epoxy was selected due to its high structural strength when cured in room temperature conditions and its ability to cure relatively quickly, within 6-8 hours. Depending on the loading conditions expected for each specimen, different CFRP layups were built up based on the chosen best configuration given by the previously run FEA models. Different configurations required different specific steps for application, but the general process was largely the same across all retrofits. Specific dimensioned swatches were cut from carbon fiber cloth to be used for the CFRP. Epoxy would be applied to the entire steel surface first. Additional epoxy was then kneaded throughout the carbon fiber swatch before placing it on the steel surface. Once placed on the steel, the carbon fiber was manipulated into the desired shape. Mold release agent was then applied to rectangular pieces of acrylic which were placed around the carbon fiber to hold the desired shape in while curing. Small clamps were placed onto the acrylic and steel to hold the acrylic false work as well as apply pressure to purge the matrix of all excess epoxy (Figure 16). Specimens were then allowed to cure at a minimum of 24 hours. To shorten this process, heat could be used to quicken the curing times of most epoxies



with some curing in as little as 20 minutes. Once specimens were cured, clamps and acrylic were carefully removed from the CFRP. Files and sand paper were used to shape the CFRP as desired. All edges were beveled at a 45° angle to help with peel and shear stresses. Retrofitted specimens were then placed into the Walter+Bai bi-axial fatigue machine and ran using the same methods as non-retrofitted specimens (3.2). Listed steps can be seen in Figure 17.



Figure 16. Layup method of CFRP showing clamps and acrylic molds

<b>Step</b>	<b>Action</b>
1	Sanded bond location to remove all mill scale
2	Prepared the bond surface of the steel using the chosen preparation method
3	Cleaned the surface using a solvent to remove all particles and oils
4	Cut out desired carbon fiber swatch
5	Applied epoxy to the bond surface of steel
6	Kneaded epoxy throughout the carbon fiber
7	Placed carbon fiber onto surface and mold into general desired shape
8	Applied mold release agent to acrylic pieces
9	Used acrylic pieces to hold the carbon fiber in place and in shape
10	Applied small clamps around acrylic false work to apply pressure and purge all excess epoxy from the matrix
11	Allowed a minimum curing time of 24 hours before any testing
12	Removed all acrylic false work
13	Cleaned all edges using disc sander
14	Beveled all edges to 45°

Figure 17. Steps taken to prepare retrofitted plate specimens

For the current scope of this research, no retrofitted tube specimens were conducted but these will be conducted in future research efforts. For these tube specimens, all above steps should be followed in a similar manner but for a tube profile, no out of plane stiffening will be needed due to the orientations of the stresses of modes I & II. However, for tube specimens, fiber orientation will need to be considered due to the stresses within the steel not being all vertical as within the plates. To find the angle of fiber orientation needed, stress orientation calculations will be conducted for the tubes based on the 500 N\*m of torsion and 50 kN of tension applied to the tubes. These retrofits would then be applied to the specimen at an angle parallel to the stress orientations found within the material at the crack tips. Within the field, fiber orientation could be

place perpendicular to the direction of the crack to align it parallel to the forces causing the crack if FEA or basic calculations were unreasonable. CFRP should be placed across the entire crack width for tubes to combat both crack edges. From a field applications point of view, the CFRP would only be applied to the single crack tip seen on the gate since the other crack tip would have most likely terminated against the beginnings or edges of the particular part on the gates.

#### 4. Results/Discussion

##### 4.1 Pintle Modeling

Below are the tabulated results of 6 elements within the pintle region model. The stresses measured here are von. Mises stresses and are all measured in kips per square inch. As can be seen, both locations, A and B show to have stress reductions. On average, an element nearest to the retrofit about the center of the length of the CFRP had 6.4 ksi lower stress. This magnitude of stress reduction is similar to stress reductions seen during the axially loaded physical experiments. These stress reductions clearly show CFRP has the ability to reduce stress within the steel of a lock gate when bonded wholly. However, it is known the bonding methods used in this research did not provide sufficient strength between the steel and CFRP to transfer the loads over many cycles to continuously hold this stress relief and supply a capable retrofit strategy.

Table 1. Retrofit vs non-retrofit stress reductions within the pintle model

Location	Element #	Non-Retrofitted (ksi)	Retrofitted (ksi)	Change (ksi)
A	6387	30.63	23.98	6.65
	6388	33.52	25.98	7.53
B	6409	36.95	30.58	6.37
	6410	44.20	36.02	8.18
	6428	40.90	35.83	5.08
	6429	45.51	40.73	4.78
Average				6.43

Additionally, a 1 ft by 2 ft rectangular piece of CFRP was modeled in a similar location as the other two retrofits to explore size effects of the CFRP retrofit. Size had an insignificant effect on the model and a stress reduction at the center of the retrofit of 2.79 ksi was observed (Table 2, Figure 18).

Table 2. Retrofit vs non-retrofit stress reductions within the pintle model for 1ft by 2ft retrofit

Element #	Non-Retrofitted (ksi)	Retrofitted (ksi)	Change (ksi)
4383	19.34	17.16	2.18
4385	21.06	18.40	2.66
4387	22.48	19.71	2.77
4389	24.02	20.83	3.19
4391	25.29	22.14	3.15
		Average	2.79



Figure 18. Larger 1ft by 2ft retrofit

#### ***4.2 FEA Modeling of Generalized Specimens to Develop CFRP Retrofits Results***

Modeling was focused upon combined loadings of the two types of specimens due to the complexity of the resulting stresses. Axial only forces would arise to in plane stresses and orientations that did not need further visualization or FEA validation to develop retrofits. Figure 19 displays the two geometries and their corresponding stress orientations for torsion forces only. For the tube specimen, all stress orientations are in plane with the material indicating flat retrofits of unidirectional fibers would suffice at an angle parallel to the stress orientations. For the plates, the stresses are oriented in a direction out of the plane of the material and for a retrofit to be effective in relieving out of plane stresses, out of plane stiffening capabilities would be needed.

Three initial out of plane stiffening retrofits were investigated using FEA to find the most stress reducing CFRP layup. A three ridged layup, a single ridged layup with a combined thickness of three ridges, and a crossed ridge layup were analytically investigated (Figure 20). Max stresses were obtained after loading to find which of these would be the best retrofit out of the three. Out of three layups, the models indicated the most stress reduction was given by the three layer single ridged layup. The cross pattern had an average stress reduction of 108.7ksi, the three separate ridge pattern, 107.7ksi and the thick single ridge had a stress reduction of 112ksi at the crack tip on elements nearest the CFRP.

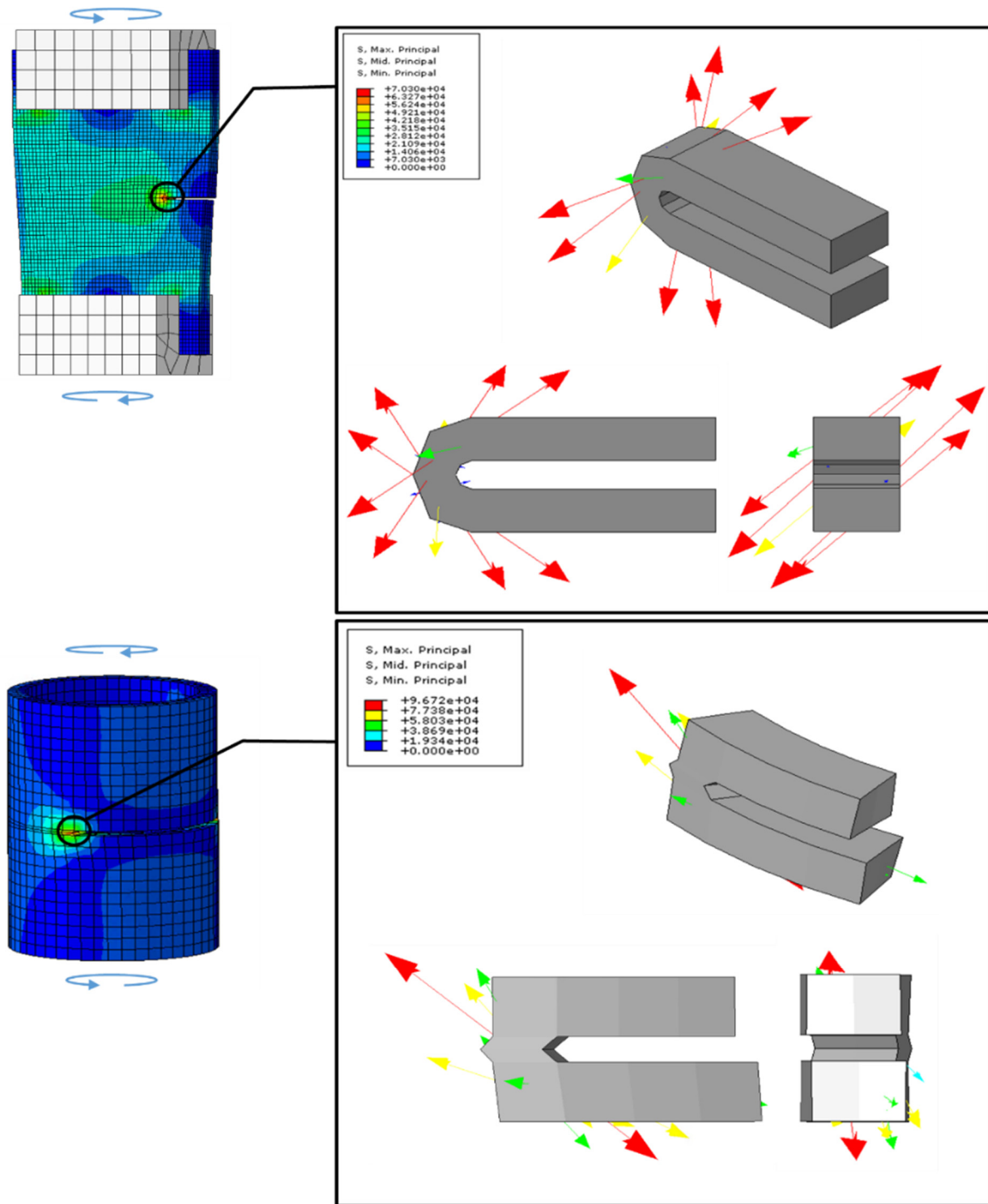

Figure 19. FEA Model visual assistance of stress orientations (Torsion Only)

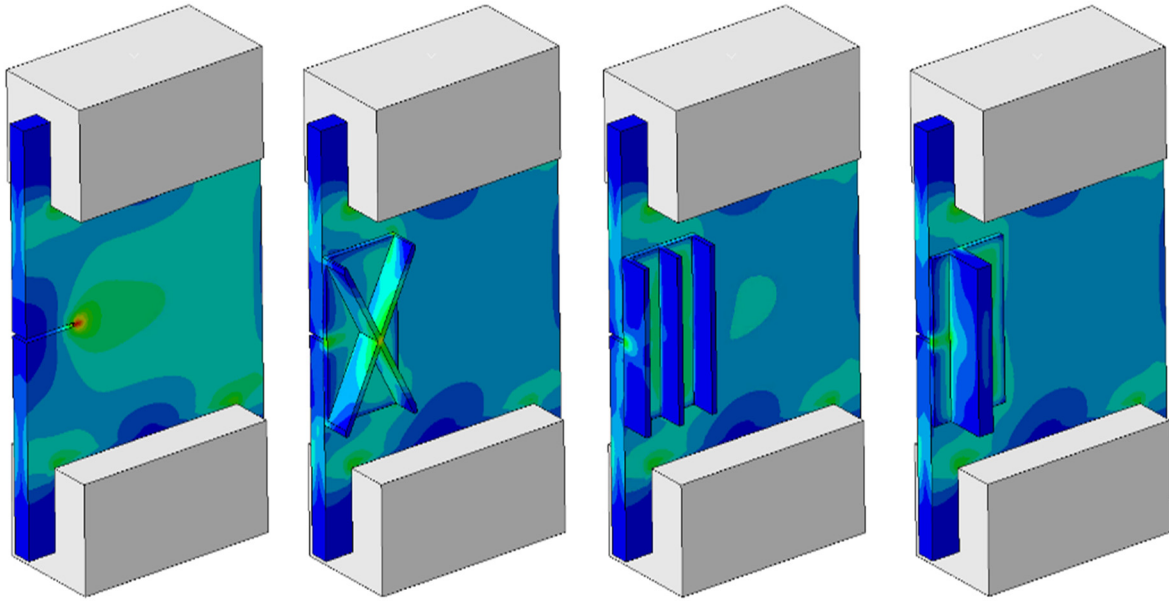

Figure 20. Contour comparisons between three different layups

An axial only FEA model was created as well for the plate where a flat unidirectional retrofit was applied. Average stress reductions at the crack tip within the model were measured as 22.1 ksi (Table 3).

Table 3. Axial Only stress reductions found within the FEA model

	Non-Retrofited Stress (ksi)	Retrofitted Stress (ksi)	Stress Reduction (ksi)
Stresses near crack tip	34.2	14.4	19.8
	44.5	19.3	25.3
	44.4	19.2	25.2
	32.4	14.1	18.3

#### 4.3 Retrofitted and Non-retrofitted Specimen Experimental Results

Table 4 shows all completed fatigue tests and the corresponding cycles to failure for each specimen tested. Multiple variables for the specimens such as crack tip length, strain gauge data for specific specimens and loading data were collected but the research was focused upon the number of cycles to “failure” of each individual specimen in order to validate the use of CFRP to

increase fatigue life when presented with multi-axial and out of plane stresses. Additional variables were only collected to help answer any future questions that might have arose when testing if phenomena were seen that were unexpected such as cycles to failure changes.

Table 4. Tabulated fatigue assessment of all tested specimens

		Number of Cycles to Failure ( $N_f$ )			
		Non-Retrofitted		Retrofitted	
		Test 1	Test 2	Test 1R	Test 2R
Plate Tests	100kN-A	304,334	272,015	829,532	1,464,362
	100kN-A+1000Nm-T	46,326	79,240	80,862	73,012
	1000Nm-T	115,970	202,148		
		Non-Retrofitted Tube Tests			
Loading Type	50kN-A	50kN-A+500Nm-T	500Nm-T		
Number of cycles to failure ( $N_f$ )	16,659	23,552	53,058		

When out of plane strain was introduced, cycles to failure showed no indications of increasing for retrofitted specimens. All plate specimens with torsion loadings had no noticeable improvements of fatigue life due to the CFRP retrofit. Thick ridge retrofitted specimens were observed to go through as few as 10 cycles before the CFRP retrofits were fully debonded from the surface of the steel, essentially creating a non-retrofitted specimen with at most, 10 additional cycles to failure. This debonding was thought to have been caused because of the large stiffness of the retrofit. Small deflections were allowed within the CFRP retrofit which in turn increased the stresses on the cohesive layer at the bond locations. These stresses were far too great for the cohesive layer to survive past any significant number of cycles. To try and fix debonding issues, additional flat retrofit tests with no extra out of plane stiffening such as those seen in axial only testing were conducted for the combined loading of plates. The hopes for these retrofits were that debonding would be reduced due to the decrease in stiffness but the retrofit would still combat mode I stresses as well as a component of mode 3 stresses and might in turn increase the cycles to



failure. While the flat retrofits did stay bonded onto the specimens for the majority of the test, no significant increase in cycles to failure were observed and it was observed that specimens developed very similar cracks as their non-retrofitted counter parts. Figure 21 through Figure 23 show the resulting fatigue crack growth observations within the plate specimens under the various uni-axial and multi-axial loadings.

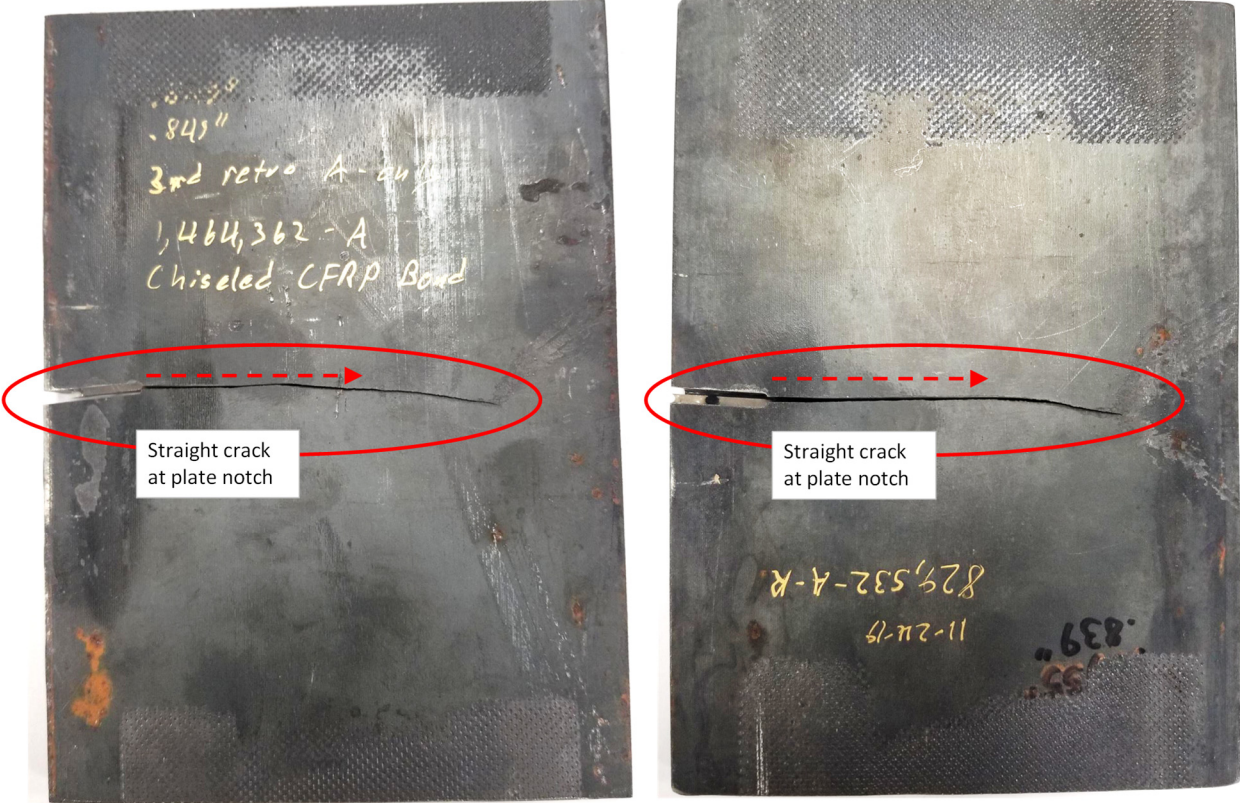

Figure 21. Resulting fatigue crack growth in uni-axially loaded un-retrofitted and retrofitted notched plate specimens.



Figure 22. Resulting fatigue crack growth in un-retrofitted and retrofitted notched plate specimens under combined axial and torsional loading.

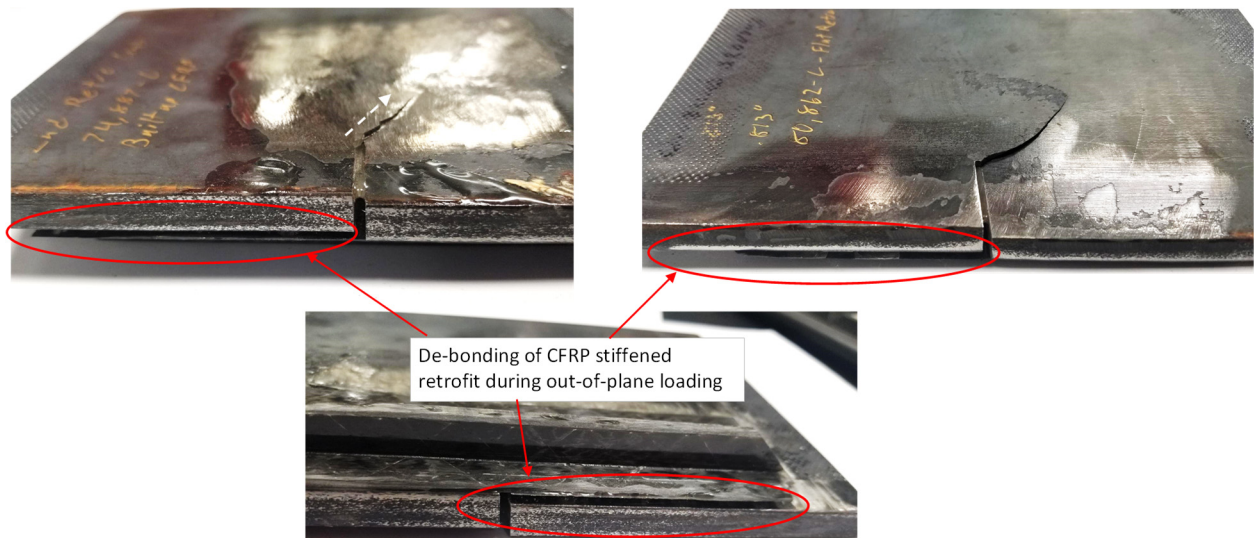

Figure 23. CFRP debonding in retrofitted notched plate specimens under combined axial and torsional loading

It is suggested to modify the ridge of the stiffened CFRP retrofit to be localized to half an inch on either side of the retrofitted crack. The localized stiffness will likely combat out of plane stresses while allowing for deflection away from the crack tip which could then help with the debonding of the cohesive layers.

Strain gauges were attached to a bare plate specimen as shown in Figure 24. This specimen was placed in the machine and ran for 5 cycles of 100 kN axial tension only. After that data was collected, axial only CFRP retrofits were applied to the plate and allowed to cure. The axial only tension was again applied to the plate and the stress reduction of the retrofits for axial only were obtained. Figure 25 shows the strain at the crack tip on the retrofitted side of the specimen before and after retrofit application. A difference of just under 4 ksi was felt at the crack tip. This stress reduction translated to a massive increase in cycles as could be seen in Table 4. 4 ksi reduction in stress is much less than the FEA reduction seen in previous models. However, the stress reduction within the models assumed a perfect bond. Additionally, the stress reduction values were obtained from the elements nearest the crack tip while the strain gauge was placed 1mm away from the crack tip. When values are probed approximately 1mm away from the crack tip, stress reductions are seen to be very similar as seen in Table 5.



(a)

(b)

Figure 24. Strain Gauge placement on (a) un-retrofitted and (b) retrofitted cracked plate

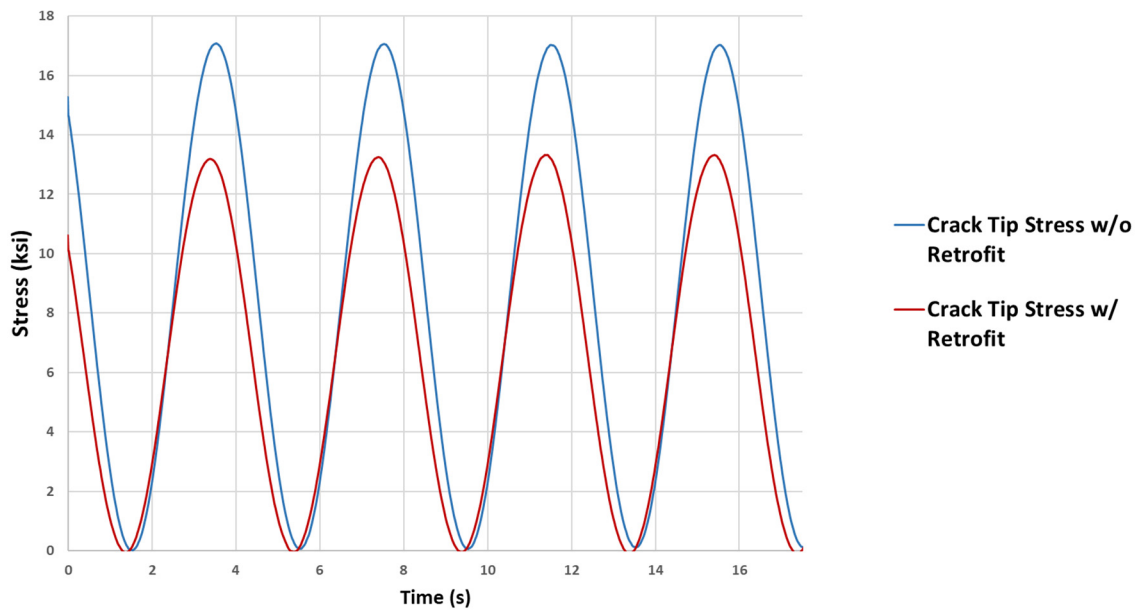

Figure 25. Crack tip stresses with and without Unidirectional CFRP Retrofit

Table 5. Stress values of an axial only plate model nearest crack vs. strain gauge location (FEA Model)

	Non-Retrofited Stress (ksi)	Retrofitted Stress (ksi)	Stress Reduction (ksi)
Near Crack tip	34.2	14.4	19.8
	44.5	19.3	25.3
	44.4	19.2	25.2
	32.4	14.1	18.3
Strain Gauge Location	18.9	10.4	8.5
	19.3	10.4	8.9
	16.8	9.1	7.7
	17.2	9.0	8.2

## 5. Conclusions

The pintle region of a lock gate is often subjected to multi-axial stresses during operation which can lead to multi-mode fatigue cracking. In this study, both detailed finite element analyses and experimental fatigue testing were used to help understand the multi-mode fatigue behavior and develop bonded CFRP retrofits to delay crack growth. The following conclusions are from the analytical and experimental study:

- 1) Analyses indicated that stiffened CFRP plates are effective at reducing multi-axial stresses within the pintle region, as long as the CFRP-to-steel bond remains intact. Experimental multi-axial fatigue testing highlighted difficulties in maintaining deformation compatibility between the steel and stiffened CFRP plates under out-of-plane loading (mode III loading), leading to debonding and negligible stress reductions for fatigue life improvement.
- 2) Roughening the steel surface prior to attaching the CFRP plates increases the CFRP-to-steel bond strength under in-plane loading.
- 3) CFRP plates were effective at extending fatigue life of the cracked steel specimens under mode I loading. For mode I loading, when the CFRP was implemented on the

pre-notched plate, a 4 ksi reduction in stress at the crack tip was measured. This stress reduction was also noticed in finite element analyses. Following the mode I retrofits, fatigue life increased by between 2.7 and 5.4 times when compared to specimens without retrofits.

- 4) Under combined loading (mode I and mode III cracking), unstiffened CFRP plates showed negligible improvement in extending the fatigue life of the cracked steel plates. Unstiffened CFRP plates were used to allow deformation compatibility with the considered adhesives and prevent debonding. The lack of out-of-plane stiffness resulted in negligible effect on crack-tip stress reduction. The effectiveness of the unstiffened plates for combined mode I and mode II cracking was not investigated; however, given that the CFRP retrofits successfully mitigated in-plane (mode I) fatigue cracking, they are likely to be effective for combined mode I and II loading as well.

## 6. References

- [1] C. Lozano, "Development of Pre-Stressed Retrofit Strategies for Mitigating Fatigue Cracking in Steel Waterway Lock Gate Components," Master of Science in Civil Engineering Masters Thesis, Civil Engineering, University of Arkansas, Fayetteville, AR, 2016.
- [2] USACE. (1999) Inland Waterway Navigation Value to the Nation. *U.S. Army Corps of Engineers*.
- [3] PortPitt. (2017). *The Port District and the Inland Waterway System*. Available: <http://www.port.pittsburgh.pa.us/index.aspx?page=127>
- [4] ISFAC. (2018). *Illinois Marine Transportation Initiative* [PowerPoint]. Available: [http://www.idot.illinois.gov/Assets/uploads/files/Transportation-System/Pamphlets-&-Brochures/Freight-Council/102918/ISFAC\\_Illinois\\_Marine\\_Transportation\\_October.pdf](http://www.idot.illinois.gov/Assets/uploads/files/Transportation-System/Pamphlets-&-Brochures/Freight-Council/102918/ISFAC_Illinois_Marine_Transportation_October.pdf)
- [5] USACE Mississippi Valley Division, "Illinois Waterway Locks and Dams: Rock Island Districts," Chicago2016.
- [6] MARAD. (2019). *America's Marine Highway Routes*. Available: <https://www.maritime.dot.gov/grants/marine-highways/marine-highway>

- [7] K. Sprague, "Unanticipated Closure of the Poe Lock," Department of Homeland Security June, 2015 2015.
- [8] P. Glass. (2012), Head Lock. *Work Boat*. Available: <https://www.workboat.com/archive/head-lock/>
- [9] S. M. J. R. Majid R. Ayatollahi, Mohd Yazid Yahya, "Mixed mode fatigue crack initiation and growth in a CT specimen repaired by stop hole technique," *Engineering Fracture Mechanics*, vol. 145, p. 13, 2015.
- [10] A. S. E. Ghafoori, M. Motavalli, "Fatigue behavior of notched steel beams reinforced with bonded CFRP plates: Determination of prestressing level for crack arrest," *Engineering Structures*, vol. 45, p. 13, December 2012 2012.
- [11] H. S. M. Tavakkolizadeh, "Fatigue Strength of Steel Girders Strengthened with Carbon Fiber Reinforced Polymer Patch," *Structural Engineering*, vol. 129, p. 11, 2003 2003.
- [12] M. M. Sivaganesh Selvaraj, "Enhancing the structural performance of steel channel sections by CFRP strengthening," *Thin-Walled Structures*, p. 13, August 2016 2016.
- [13] M. J. C. Trent C. Miller, Dennis R. Mertz, Jason N. Hastings, "Strengthening of a steel bridge girder using CFRP plates," *Bridge Engineering*, vol. 6, p. 9, November 2001 2001.
- [14] C. Labashosky, "Markland Gate Failure," ed. Flickr.com: USACE, 2011.
- [15] S. Goodeyon. (2014, In-house crews finish major Lock & Dam 14 maintenance ahead of schedule. Available: [https://www.army.mil/article/135171/in\\_house\\_crews\\_finish\\_major\\_lock\\_dam\\_14\\_maintenance\\_ahead\\_of\\_schedule](https://www.army.mil/article/135171/in_house_crews_finish_major_lock_dam_14_maintenance_ahead_of_schedule)
- [16] Abaqus/Cae, "User's Guide," vol. 6.14, ed, 2017.
- [17] J. T. D. Fernando, T. Yu, X. Zhao, "Preperation and Characterization of Steel Surfaces for Adhesive Bonding," ed. ASCE Library, 2013.